

DIN 2573

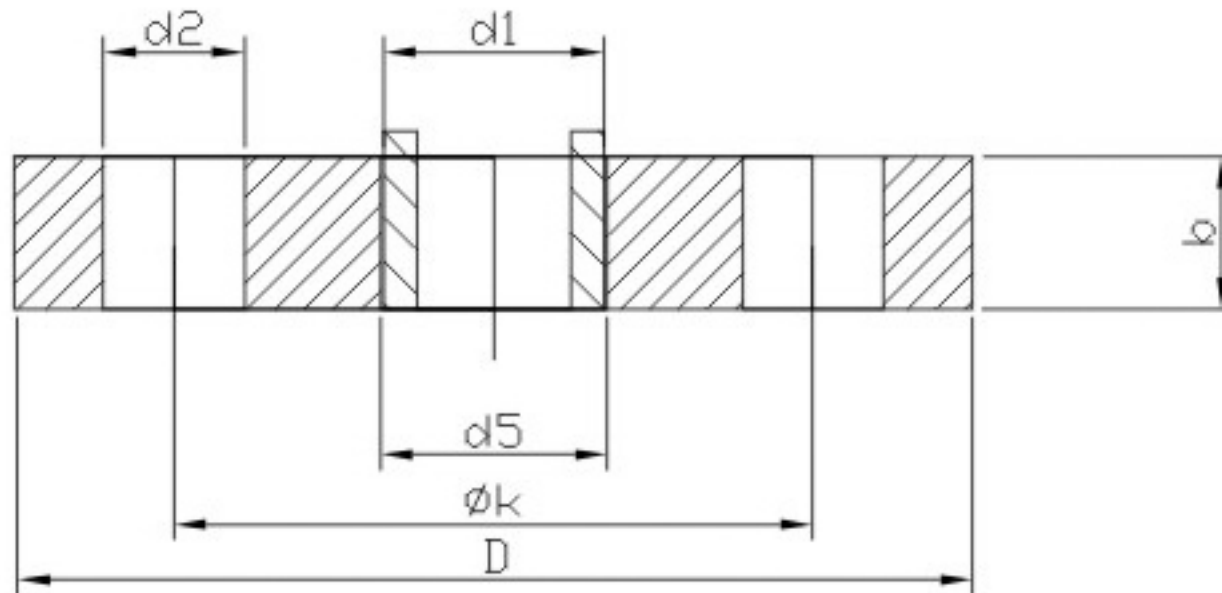

Slip-on Flange 6 bar

Nominal	Pipe Size		Flange Dimensions				Bolt Pattern			Weight
	d1 std	d1 opt	d5	D	b	k	Holes	Bolt Dia	d2	lbs
10	-	14	14.5	75	12	50	4	M10	11	0.80
	17.2	-	17.7							
15	-	20	21	80	12	55	4	M10	11	0.90
	21.3	-	22							
20	-	25	26	90	14	65	4	M10	11	1.32
	26.9	-	27.6							
25	-	30	31	100	14	75	4	M10	11	1.63
	33.7	-	34.4							
32	-	38	39	120	16	90	4	M12	14	2.62
	42.4	-	43.1							
40	-	44.5	45.5	130	16	100	4	M12	14	3.06
	48.3	-	49							
50	-	57	58.1	140	16	110	4	M12	14	3.37
	60.3	-	61.1							
65	76.1	-	77.1	160	16	130	4	M12	14	4.17
80	88.9	-	90.3	190	18	150	4	M16	18	6.57
100	-	108	109.6	210	18	170	4	M16	18	7.63
	114.3	-	115.9							
125	-	133	134.8	240	20	200	8	M16	18	10.14
	139.7	-	141.6							
150	-	159	161.1	265	20	225	8	M16	18	11.51
	168.3	-	170.5							
200	219.1	-	221.8	320	22	280	8	M16	18	15.76
250	-	267	270.2	375	24	335	12	M16	18	21.19
	273	-	276.2							
300	323.9	-	327.6	440	24	395	12	M20	22	27.78
350	355.6	-	359.7	490	26	445	12	M20	22	34.39
	-	368	372.2							
400	406.4	-	411	540	28	495	16	M20	22	40.56
	-	419	423.7							
450	457	-	462.3	595	30	550	16	M20	22	47.18
500	508	-	513.6	645	30	600	20	M20	22	54.23