

DIN 2630

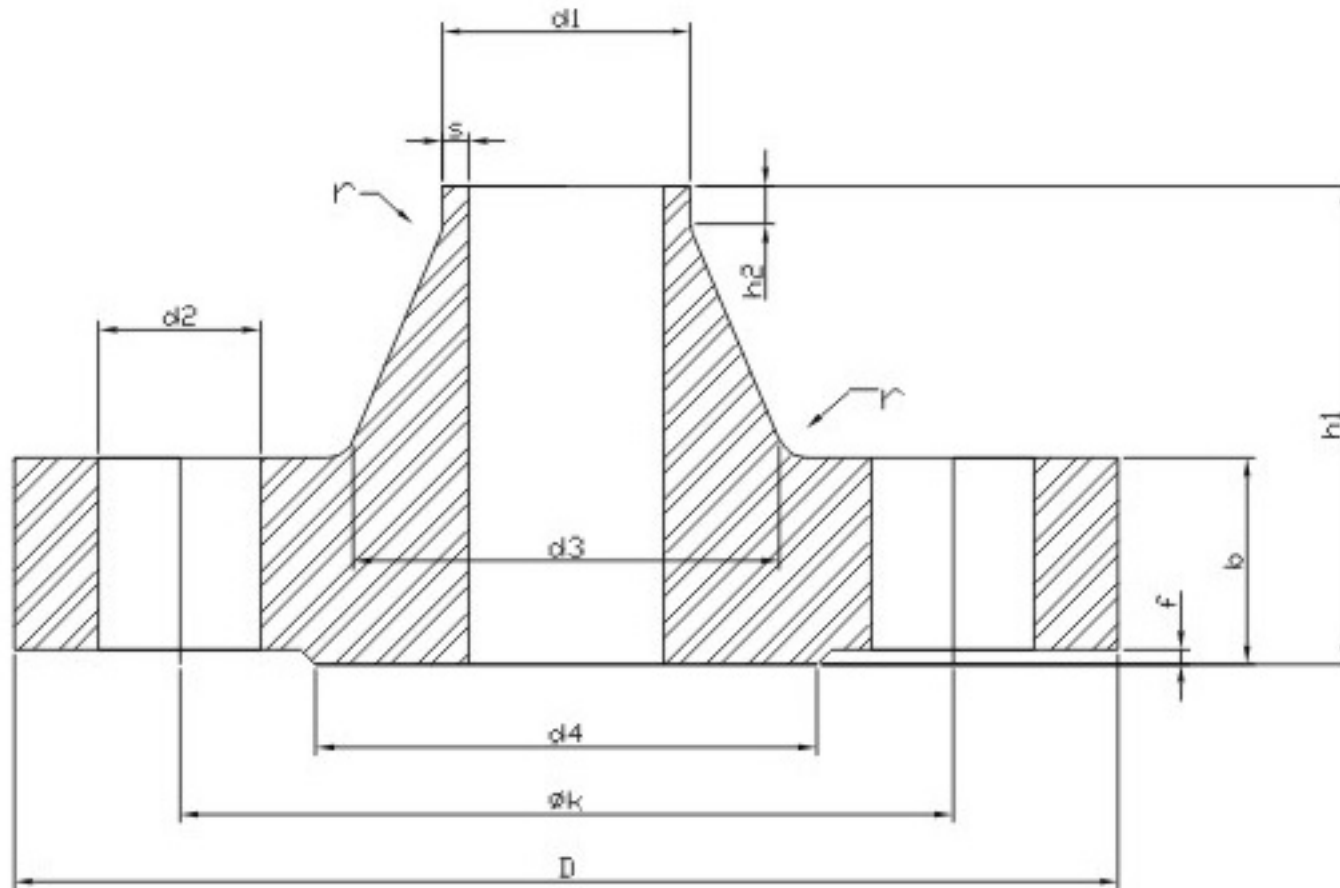

Weldneck Flange PN1 & PN2.5

Pipe Size		Flange Dimensions				Beginning Dimensions				Raised Face		Bolt Pattern			Weight
Nominal	d1 std	D	b	k	h1	d3	s	r	h2	d4	f	Holes	Bolt Dia	d2	lbs
10 - 1000	For Flanges 10 - 1000, See PN6														
1200	1220	1375	26	1320	70	1245	7	16	16	1280	5	32	M27	30	162.92
1400	1420	1575	26	1520	70	1445	7	16	16	1480	5	36	M27	30	188.27
1600	1620	1790	26	1730	80	1645	8	16	20	1690	5	40	M27	30	238.10
1800	1820	1990	26	1930	80	1845	9	16	20	1890	5	44	M27	30	275.58
2000	2020	2190	26	2130	80	2045	10	16	22	2090	5	48	M27	30	304.24
2200	2220	2405	28	2340	90	2248	10	18	25	2295	6	52	M30	33	379.20
2400	2420	2605	28	2540	90	2448	10	18	25	2495	6	56	M30	33	432.11
2600	2620	2805	28	2740	90	2648	10	18	25	2695	6	60	M30	33	447.54
2800	2820	3030	30	2960	90	2848	10	18	25	2910	6	64	M33	36	571.00
3000	3020	3230	30	3160	90	3050	10	18	25	3110	6	68	M33	36	643.75
3200	3220	3430	30	3360	90	3250	10	20	25	3310	6	72	M33	36	648.16
3400	3420	3630	32	3560	95	3450	10	20	28	3510	6	76	M33	36	729.73
3600	3620	3840	32	3770	100	3652	10	20	28	3720	6	80	M33	36	886.26
3800	3820	4045	34	3970	100	3852	10	20	28	3920	6	80	M36	39	917.12
4000	4020	4245	34	4170	100	4052	10	20	28	4120	6	84	M36	39	963.42